

Welcome!

We are so glad you are here!

We will get started shortly.
In the meantime, we invite you to intentionally enter this space.



Silence your cell phone



Stretch



Close the door



Take a few deep breaths



Close browser windows



Emotionally release your to-do list



Check your audio and video



Take a bio break

Fatherhood Learning Academy – Session 3

Tuesday, September 28 2021 || 2:00pm to 4:00pm ET

A photograph of a man with a shaved head, wearing a yellow t-shirt, holding a baby in a grey onesie. They are in a bright, modern living room with a white sofa and large windows in the background. The man is looking at the baby with a gentle expression.

Fatherhood Learning Academy

Session 3

September 28, 2021

HEALTHY
start
TA & SUPPORT CENTER



NICHQ
National Institute for
Children's Health Quality

Agenda

Housekeeping	Lisa Hong, NICHQ
Learning Academy Overview	Danisha Charles, NICHQ
Welcome	Kenn Harris, NICHQ
Check-In and Session Overview	Dr. Jeffery Johnson, NPCL
The Cornerstones of Evidence-Based Fatherhood: An Introduction	Dr. Herb Turner, Analytica Inc. Mr. Uriel Johnson, NPCL
Homework Assignment Review	Breakout Groups
Q&A	All
Homework & Next Steps	Danisha Charles, NICHQ

Meeting Logistics



- This session is being recorded.
- All participants are muted upon entry. We ask that you remain muted to limit background noise.
- Members are encouraged to participate in the discussion by typing your comments or asking questions using the chat box.

Connecting to the Audio Conference

- Join the Zoom Meeting by **clicking the Zoom Meeting link** & launching the Zoom application
- An audio conference box will appear
 - If you do not see the box, click **'Join Audio'**
- From the audio conference box, select **'Phone Call'** or **'Computer Audio'**
 - If using the phone:
 - Dial one of the given numbers next to **"Dial"**
 - You will be prompted to enter the **Meeting ID**
 - Then you will be prompted to enter the **Participant ID**

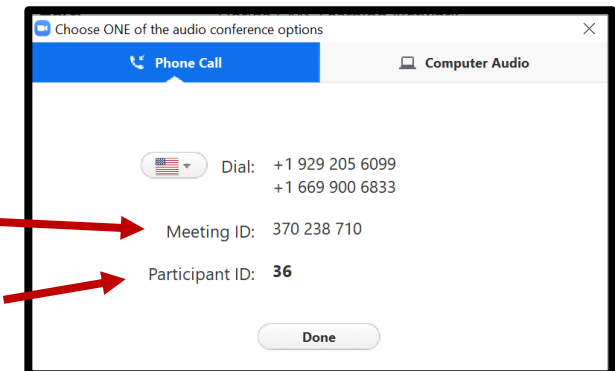
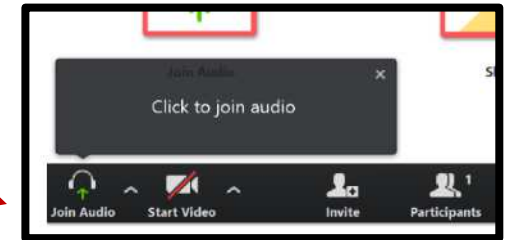
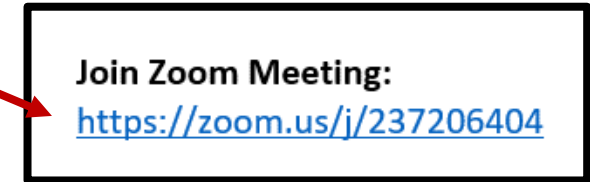

How to Chat

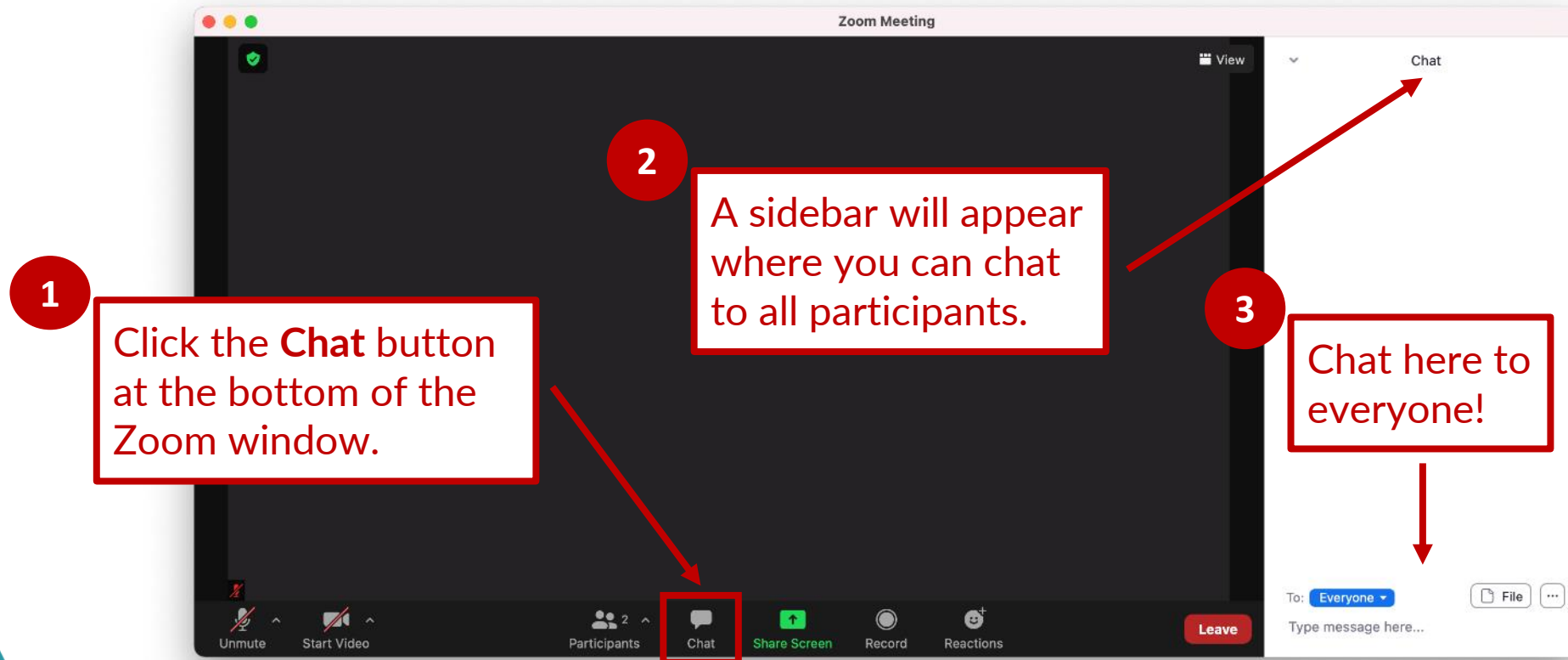

**Welcome back
to the
Healthy Start
Fatherhood
Learning
Academy!**



Healthy Start Learning Academies



Healthy Start Learning Academies provide an opportunity for HS grantees to participate in curriculum-based courses on specific topics associated with the four HS approaches and 19 HS benchmarks. Learning Academies build HS staff knowledge and prepare them to apply their learnings to their HS program's day-to-day activities.

Learning Academy Structure

- Monthly virtual sessions
- Required readings
- Homework assignments
- In the future, all sessions will be posted on EPIC in an e-learning format for those who cannot attend the live sessions



Fatherhood Learning Academy



Goal:

To examine the breadth and depth of fatherhood movement in the 20th and 21st century, deeply examining the policies and practices that have influenced fatherhood programming that have either encouraged or impeded father engagement.

Fatherhood Learning Academy Schedule



Session #1	July 27, 2-4 pm ET
Session #2	August 24, 2-4 pm ET
Session #3	September 28, 2-4 pm ET
Session #4	October 26, 2-4 pm ET
Session #5	November 23, 2-4 pm ET

Fatherhood Learning Academy

Session Topics

- Session 1* Overview of the Fatherhood Learning Academy
- Session 2* Implementing Fatherhood at the Community Level: Bringing the Program to Life
- Session 3* Managing Data and Program Evaluation: Cornerstones of Fatherhood Programming
- Session 4* Child Support
- Session 5* Diversity and Fatherhood

Use the [Jamboard](#) to share your thoughts throughout the Learning Academy session

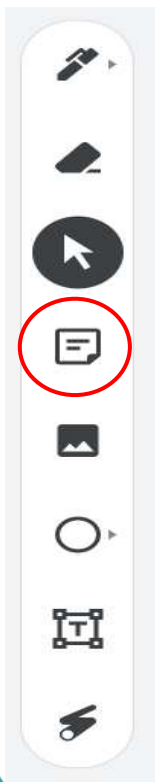

- Click the link in the chat box to access the Jamboard.
- Look to the left-hand toolbar and click the **Sticky Note** button.
- Type your response and click **Save**. Once a sticky note is posted, you can move it around on the board.
- There will be a separate page for each stage.



Welcome

Kenn Harris
Healthy Start TA & Support Center



Pre-Session Readiness Assessment

Fatherhood Learning Academy Dean



Dr. Jeffery Johnson
President & CEO,
National Partnership for Community Leadership

Homework Review

Key People, Organizations, Legislation, Court
Decisions In The History of the Fatherhood
Movement and Bringing the Fatherhood
Program to Life (Interactive Q&A)



The Cornerstones of Evidence-Based Fatherhood: An Introduction

Dr. Jeffery Johnson
President & CEO, NPCL
Dean, Fatherhood Learning Academy

Dr. Herbert M. Turner, III
President & Principal Scientist,
Analytica, Inc.

Mr. Uriel Johnson
Vice President for Research, NPCL



The Fatherhood Learning Academy is hosted by the Healthy Start TA & Support Center at NICHQ.

The Cornerstones of Evidence-Based Fatherhood: An Introduction

The Fatherhood Learning Academy

Dr. Herbert M. Turner, III
President & Principal Scientist,
Analytica, Inc.

Mr. Uriel Johnson
Vice President for Research,
NPCL

September 28, 2021



Webinar Overview

- Presenters
- Learning Objectives
- Topics: 2:30 – 3:15 pm
 - What is the nature and structure of a fatherhood program?
 - What is a fatherhood program?
 - What makes a fatherhood program evaluable?
 - What makes a fatherhood program sustainable?
 - The Cornerstones of a Fatherhood Program
- Breakout Groups (Discuss Homework): 3:15 – 3:35 pm
- Questions and Answer: 3:35 – 4:00 pm

Meet today's presenters



Dr. Herb Turner
President & Principal Scientist
Analytica, Inc.



Mr. Uriel Johnson
Vice President of Research
NPCL

Biographical Highlights:

- 30 years experience using rigorous and scientific research
- Adjunct Professor of Quantitative Methods
- National expert on “what works” evaluations, systematic reviews, and meta-analyses
- Trainer for Institute of Education Science’s What Works Clearinghouse (WWC)
- Technical and Methodological Advisor to evaluations funded by IES, NSF, and Social Innovation Fund (SIF).

Biographical Highlights:

- 30 Years of experience in fatherhood development
- A former college professor of Political Science
- Leads NPCL’s research and evaluation
- National expert on fatherhood programming
- Co-directed the “Partnership for Fragile Families” and “Fathers at Work” demonstrations
- PI on NPCL’s healthy marriage and relationship education projects

Learning Objectives

- Gain an understanding of the cornerstones (as principles) of a fatherhood program that makes it evaluable.
- Gain an understanding of what it means for a fatherhood program to be evaluable and the tiers of program evaluation of federally funded programs:
 - Evidence of Promise
 - Evidence of Effectiveness
 - Evidence of Scalability
- Test your understanding by completing the homework assignment before the session, answering knowledge checks during the session, and discussing the assignment as group during the breakout.

The Healthy Start (HS) Context

- **Evaluation Research**

- The Healthy Start grantees are required to have a local evaluation plan.
- Many grantees have other staff that supports evaluation, such as epidemiologists, data managers, coordinators, and analysts.
- Some grantees do have a local evaluator that leads the work to ensure federal reporting requirements are met.

- **Status**

- Grantees negotiated and managed evaluation activities locally.
- For each HS site, there are data reporting requirements that must provide as a requirement for their funding.

- **Benchmarks**

- Grantees submit monthly and annual data on benchmarks for entry into the federal data system.

HS Program Characteristics

Program Status

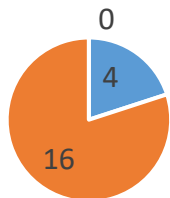

- Start-up (0-1 yr)
- New (1-3 yrs.)
- Established (3+yrs.)

Fatherhood Program Knowledge/Experience

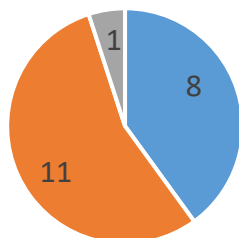

- None/Very Little
- Some/Good Amount
- Solid/Extensive

- Relatively New: 1 – 3 years in operation
- Staff has “Some” to “Good” Amount of Knowledge
- Lead by Project Director of Program Coordinator

Title/Position

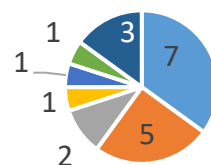

- Project Director
- Program Coordinator
- Case Manager
- Education Manager
- Nurse Navigator
- Engagement Specialist
- Unknown

1. What is the Nature and Structure of Fatherhood Programs?

The Primary Goals of Fatherhood Programs

1. Aim to address responsible fatherhood issues, attempt to address these issues through high-quality service delivery, and aspire to continuously improve through systematic observation, data collection, analysis.

2. Grow the fatherhood program to participate in rigorous evaluations starting with “evidence of promise” with the goal of producing “evidence of effectiveness” (i.e., evidence of What Works).

Data Driven Decisions, Improvement & Evaluation

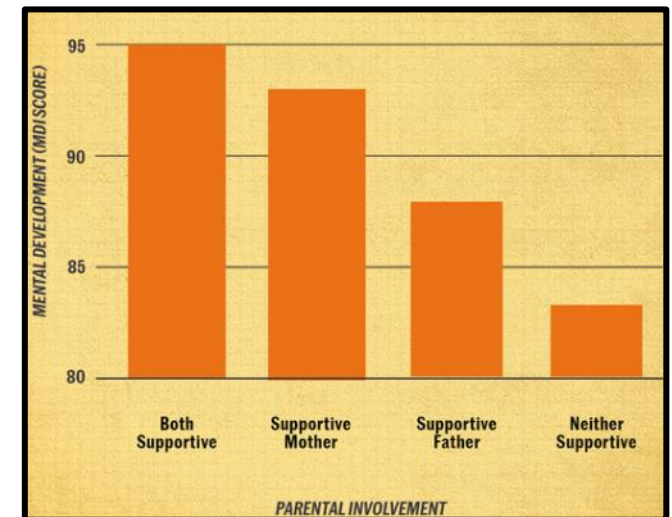

The Basic Building Blocks of Responsible Fatherhood Programs:

- Aligned curriculum
 - Well-trained staff
-
- Mature management information system
 - Targeted marketing strategy
 - Proactive recruiting and developed referral network
-
- Family friendly agency
 - Adequate resource
 - Credibility in community served
 - Shared vision of fatherhood as transformational

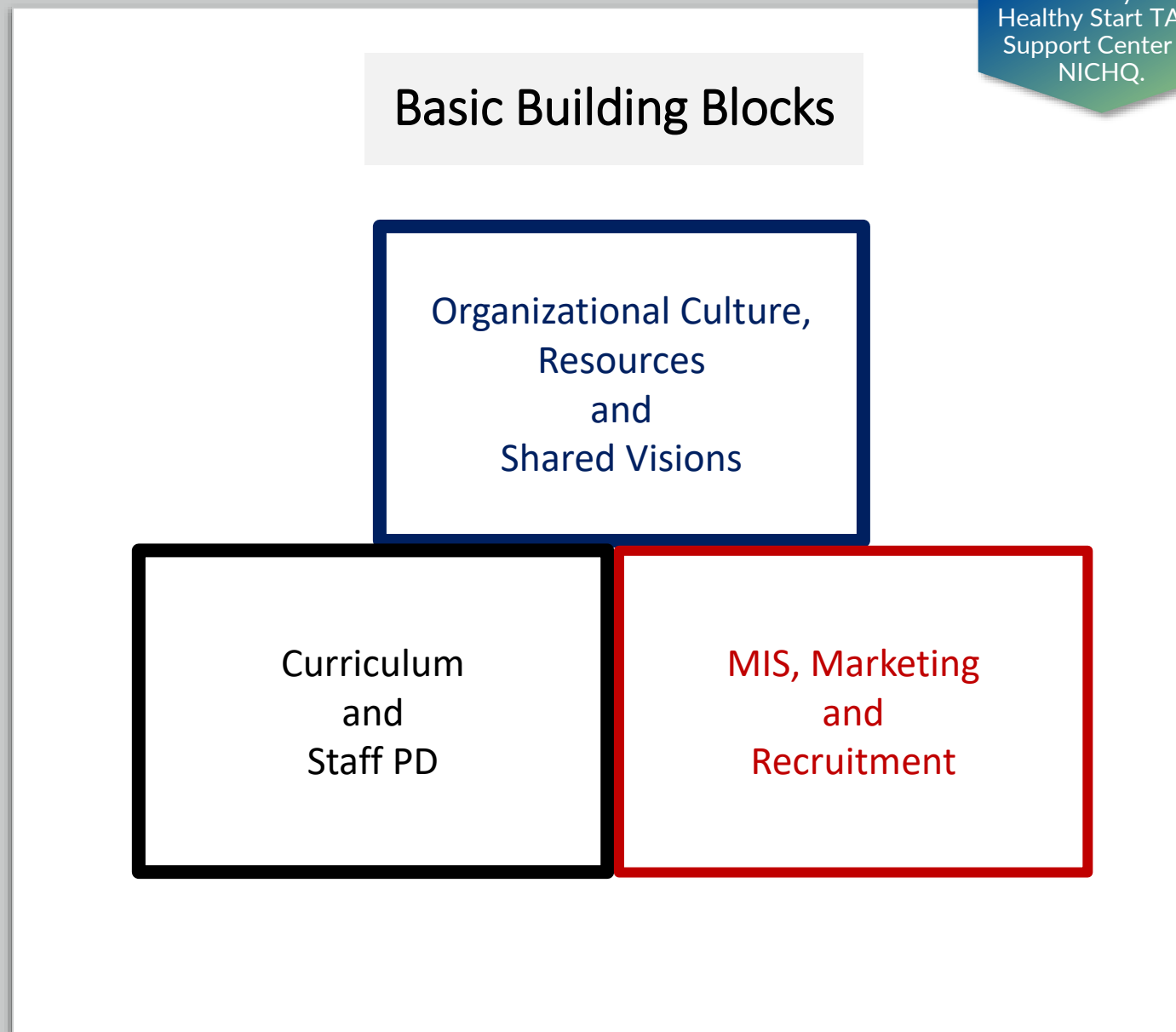

Knowledge Check: Nature and Structure of Fatherhood Programs

Q1. Quality is the sole key ingredient for a successful fatherhood program. If the program quality is high, its reputation in the community will result in fathers signing up for the program.

True

False

Answer: False. The basic building blocks, just described, must be in place with constant outreach and retention efforts.



Knowledge Check: Nature and Structure of Fatherhood Programs?

Q2. For the greatest chance of success, recruitment of fathers should be based on one of the following:

- A. Luck
- B. Word of Mouth
- C. Hard Work
- D. Personal and Professional Connections
- E. Evidence-Based Approaches
- F. None of the Above

Answer: “E. Evidence-Based Approaches” that embodies a wide range of approaches based on evidence that they work!



2. What is a Fatherhood Program?

Starting Point: Theory of Change and Logic Model

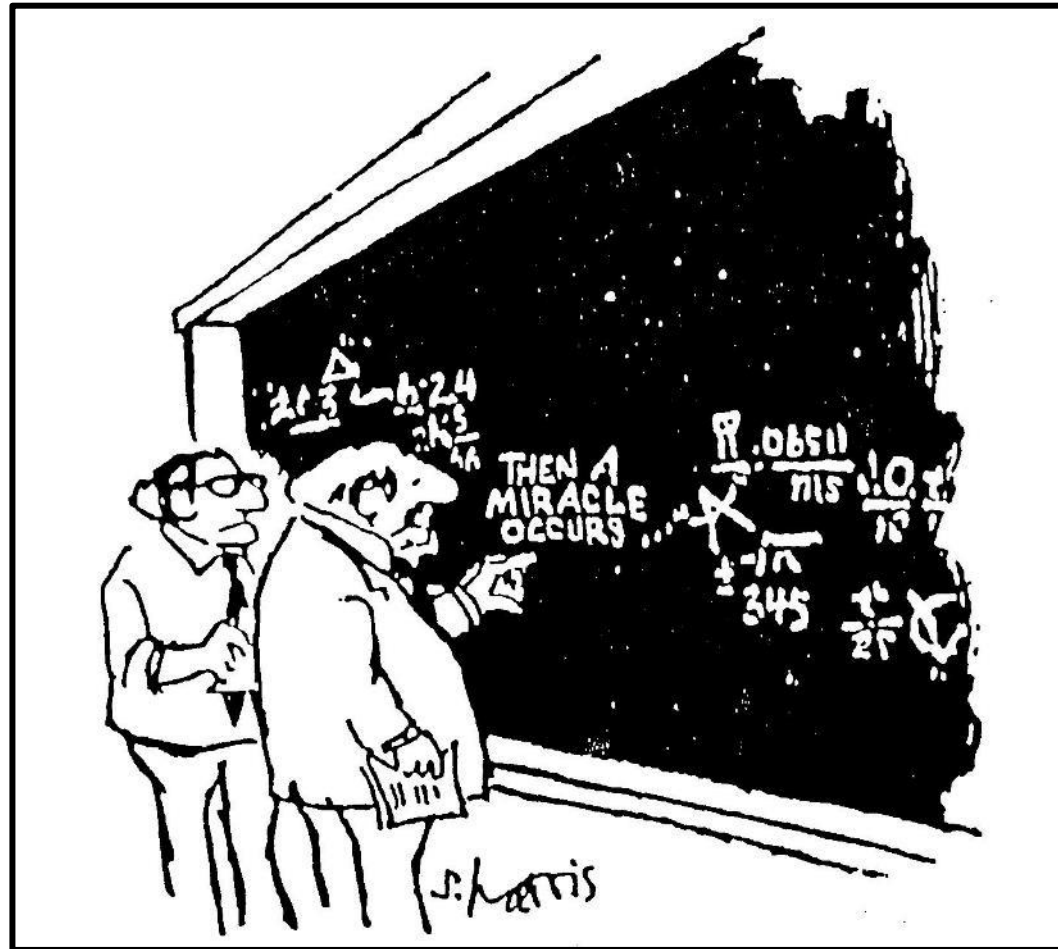

"I think you should be more explicit here in Step Two."

Theory of Change and Logic Model

- The Theory of Change presents the high level and “big picture” of how the program is expected (or theorized) to work at a *strategic level*.
- The Logical Model also illustrates how the program is expected (or theorized) to work but at the *program implementation level to understand the change process and paths*.

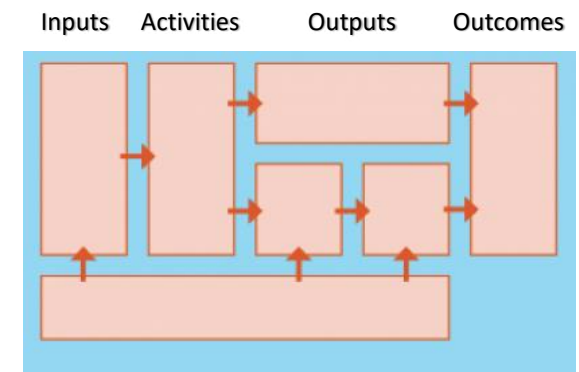

A Guide for Developing a Fatherhood Program Theory of Change

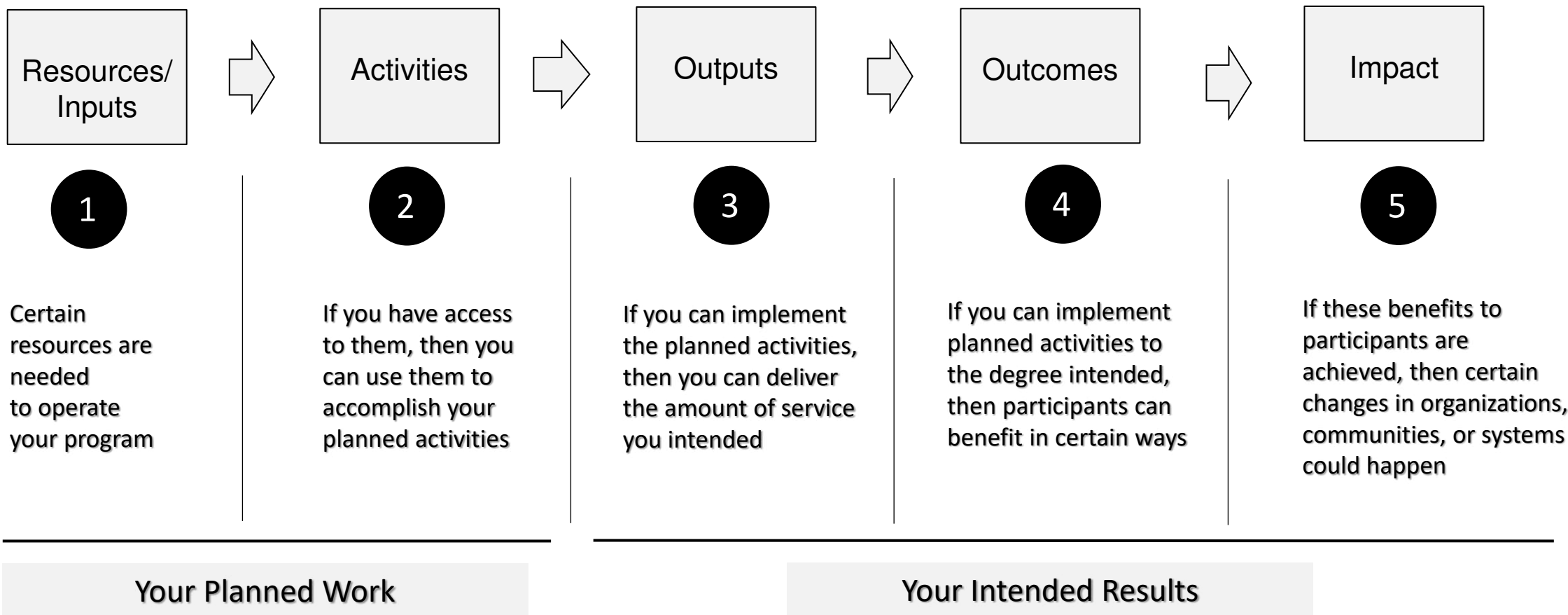

Example of a Fatherhood Development Workshop Logic Model (1.0)

The Fatherhood Learning Academy is hosted by the Healthy Start TA & Support Center at NICHQ.

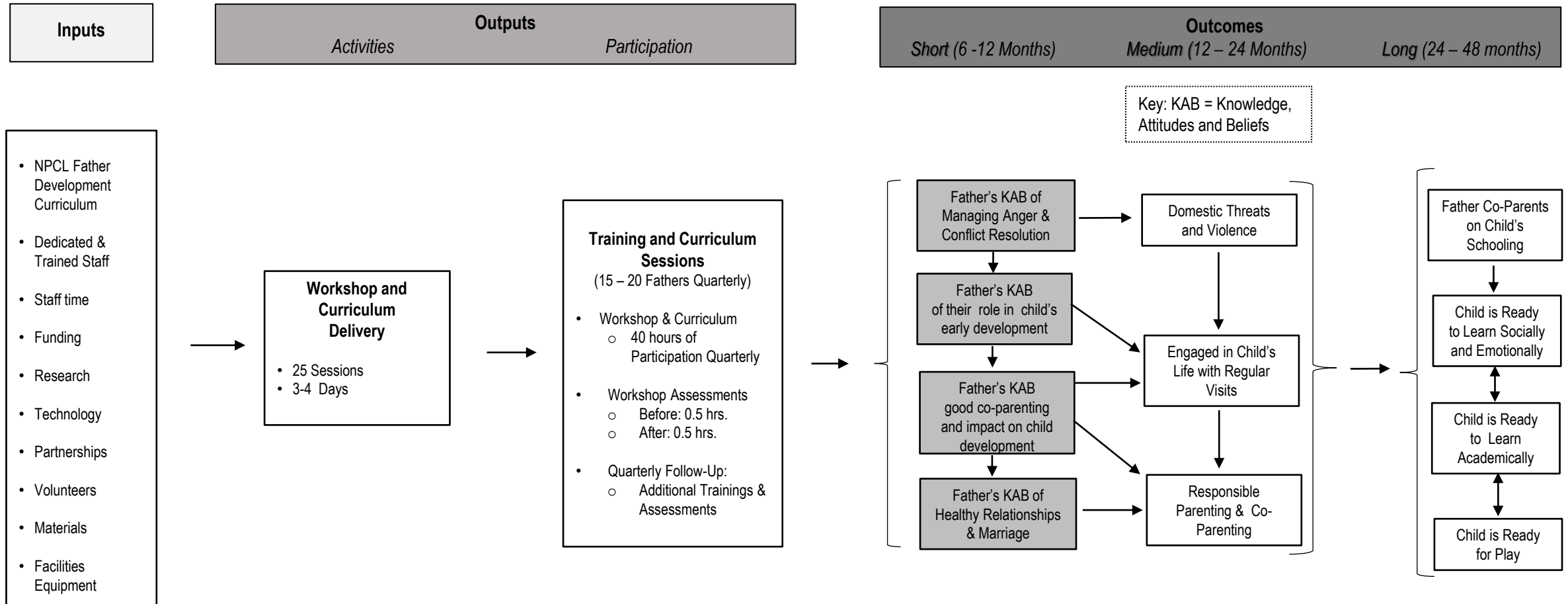

Knowledge Check: What is a Fatherhood Program?

Q1. The Theory of Change and the Logic Model are interchangeable, or one in the same. Therefore, when describing your program use either one.

True

False

Answer: False. They describe different levels of the change process. The Logic Model is specifically used to describe program level change at the participant level.



Knowledge Check: What is a Fatherhood Program?

Q2. What is the difference between the Theory of change (ToC) and Logic Model (LM)?

- A. Both present the same idea. The Difference is just Labeling.
- B. ToC presents the program change process and LM presents the big strategic picture.
- C. ToC presents the program change process and LM presents the logic.
- D. ToC present the big strategic picture and LM presents the program change process.
- E. None of the Above

Answer: D



3. What Makes a Fatherhood Program Evaluable?

Research or Evaluation: What's The Difference?

In Theory

- Research: Primary goal is to contribute to knowledge
- Evaluation: Primary goal is to assess merit, value or worth of program, policy or practice (i.e., an intervention)

In Practice

- Difference between the two is blurred or integrated
- Evaluation Research: Goal is to both contribute to knowledge and assess merit, value or worth of an intervention.

Research or Evaluation: What's The Difference?

Hereafter, for the purpose of the presentation:

Research = Evaluation = **Evaluation Research**

Scientifically Valid Evaluation Research:

Not Complex Statistical Methods!

Six Scientific Principles

1. Pose Significant Questions That Can Be Investigated Empirically
2. Link Research to Relevant Theory
- 3. Use Methods That Permit Direct Investigation of the Question**
4. Provide a Coherent and Explicit Chain of Reasoning
5. Replicate and Generalize Across Studies
6. Disclose Research to Encourage Professional Scrutiny and Critique



Federally Funded Research: Evaluation Segments

The Fatherhood Learning Academy is hosted by the Healthy Start TA & Support Center at NICHQ.

Evaluation Domains	Evaluation Purposes	Evaluation Phases	Evaluation Methods	Evaluation Designs
<div style="border: 1px solid black; padding: 5px; text-align: center;"> What's Promising? </div>	<div style="background-color: #e0e0e0; padding: 5px; text-align: center;"> Develop and Improve the Intervention </div>	<ol style="list-style-type: none"> 1. Foundational 2. Early-Stage or Exploratory 3. Design and Development 	<div style="background-color: #e0e0e0; padding: 5px;"> <ul style="list-style-type: none"> Descriptive Correlational Predictive </div>	<div style="border: 1px dashed black; padding: 5px; text-align: center;"> One-Group: Pretest/posttest </div>
<div style="border: 1px solid black; padding: 5px; text-align: center;"> What Works ? </div>	<div style="background-color: #e0e0e0; padding: 5px; text-align: center;"> Evaluate the Intervention </div> <div style="background-color: #e0e0e0; padding: 5px; text-align: center;"> Scale-Up the Intervention </div>	<ol style="list-style-type: none"> 4. Efficacy: Ideal Conditions 5. Effectiveness: Real World 6. Scale-up Study: Generalizable 	<div style="background-color: #e0e0e0; padding: 5px;"> <ul style="list-style-type: none"> Causal RCT: Experiment QED: Quasi-Experiment </div>	<div style="border: 1px dashed black; padding: 5px; text-align: center;"> Two Groups Program Group vs. Comparison Group </div>

Source: Common Guidelines for Educational Research and Development: Institute for Education Sciences and National Science Foundation

Federally Funded Research: Domains and Phases of Evaluation

What's *Promising*
or
What *Works*?

Federally Funded Research: Domains and Phases of Evaluation

What's *Promising*? (No Comparison Group)

Did the Program Cause This Gain?

Table 1. Results from a Hypothetical Fatherhood Program

Evidence of “Promise” or “What Works”?

RQ. Is the 26-point Gain in Grade 5 Reading Scores Caused by or Related to the Program?

Note. RQ = Research Question.

Outcome measure	Program group mean	Comparison group mean	Estimated difference	p-value	95 % confidence interval
Pretest score	621.46				
Posttest score	647.41				
Gain Score	25.95				

Child Outcome for Hypothetical Fatherhood Program

Child Reading Test Scores

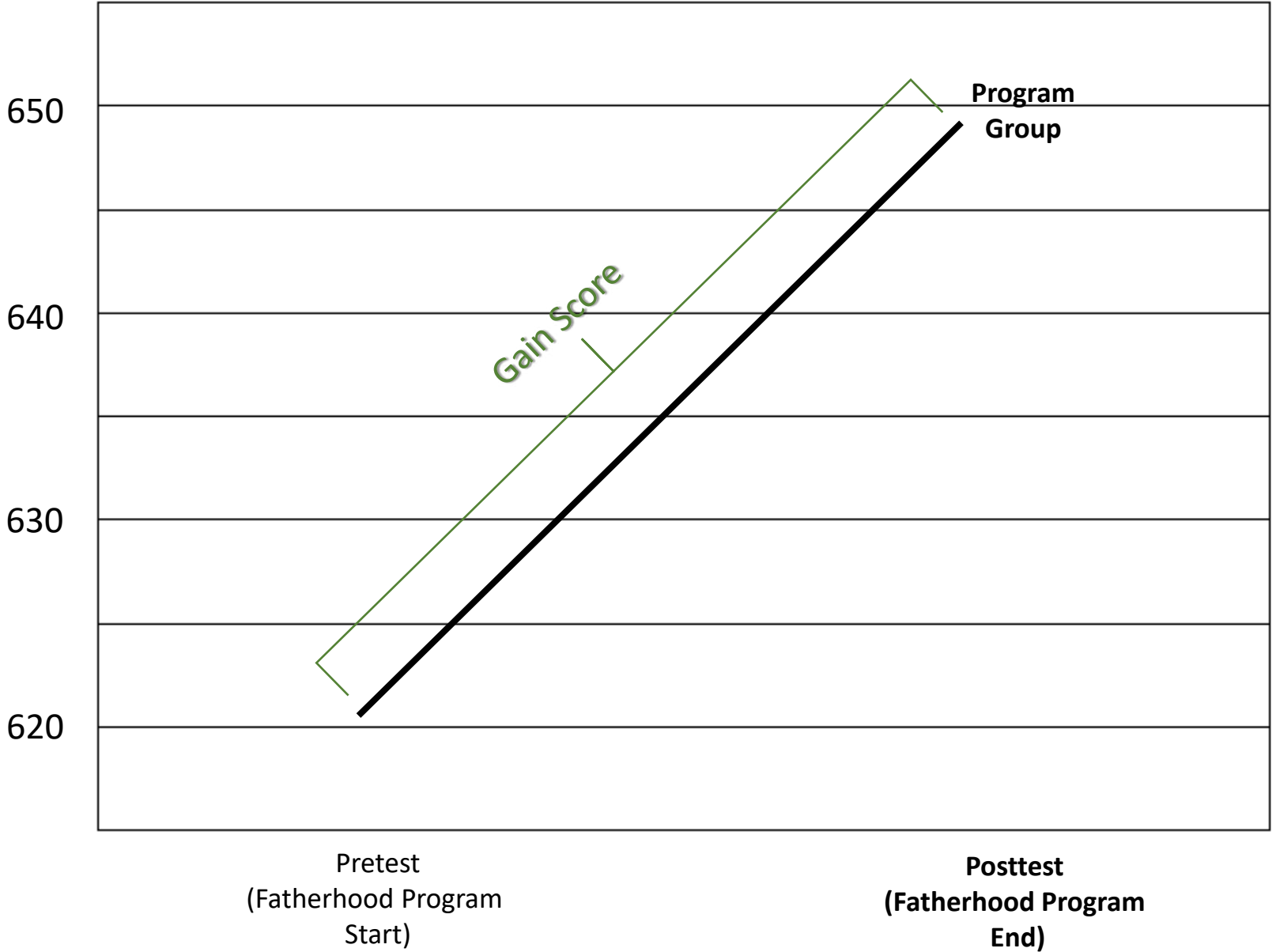

Federally Funded Research: Domains and Phases of Evaluation

What Works? (A Comparison Group)

Child Outcome for Hypothetical Fatherhood Program

The Fatherhood Learning Academy is hosted by the Healthy Start TA & Support Center at NICHQ.

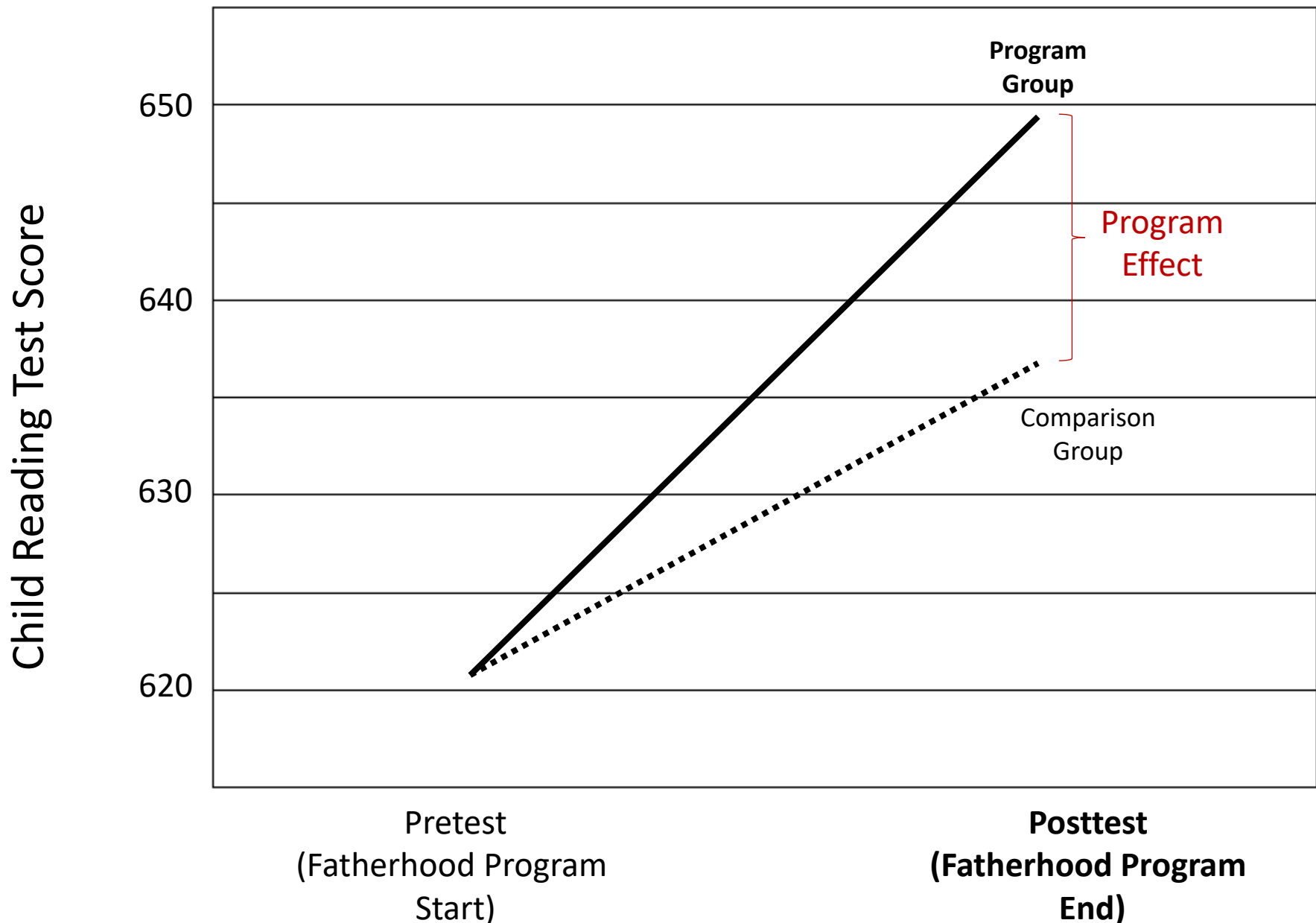

What Does a Comparison Group Tell You?

Table 1. Results from a Hypothetical Fatherhood Program

Evidence of “Promise” or “What Works”?

RQ. Is the 26-point Gain in Grade 5 Reading Scores Caused by or Related to the Program?

Note. RQ = Research Question.

Outcome measure	Program group mean	Comparison group mean	Estimated difference	p-value	95 % confidence interval
Pretest score	621.46				
Posttest score	647.41				
Gain Score	25.95				

Child Outcome for Hypothetical Fatherhood Program

The Fatherhood Learning Academy is hosted by the Healthy Start TA & Support Center at NICHQ.

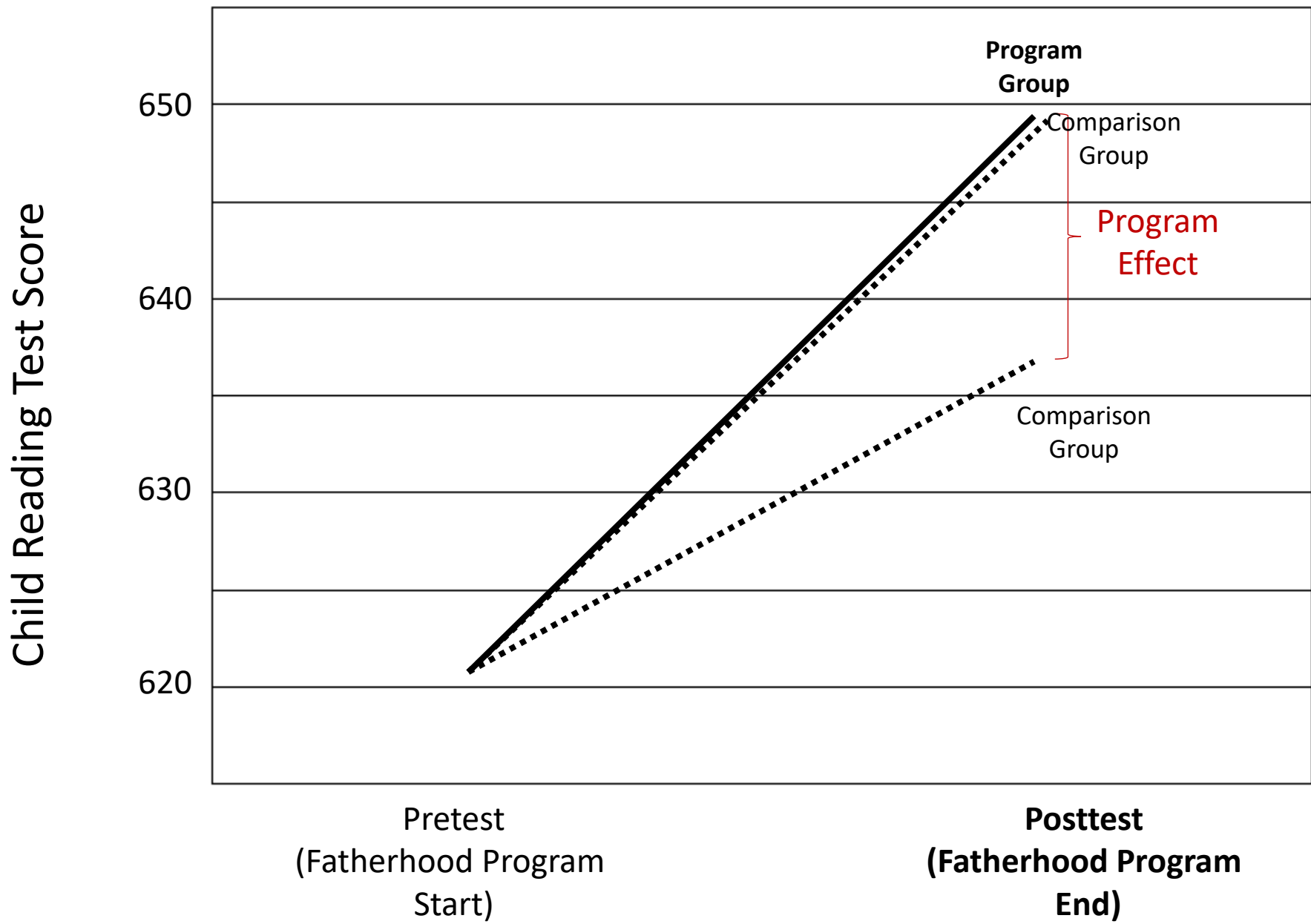

What is an RCT or QED?

DESIGN PHASE

ANALYSIS & Reporting PHASE

How Are The Groups Formed?

How Were The Groups Formed?

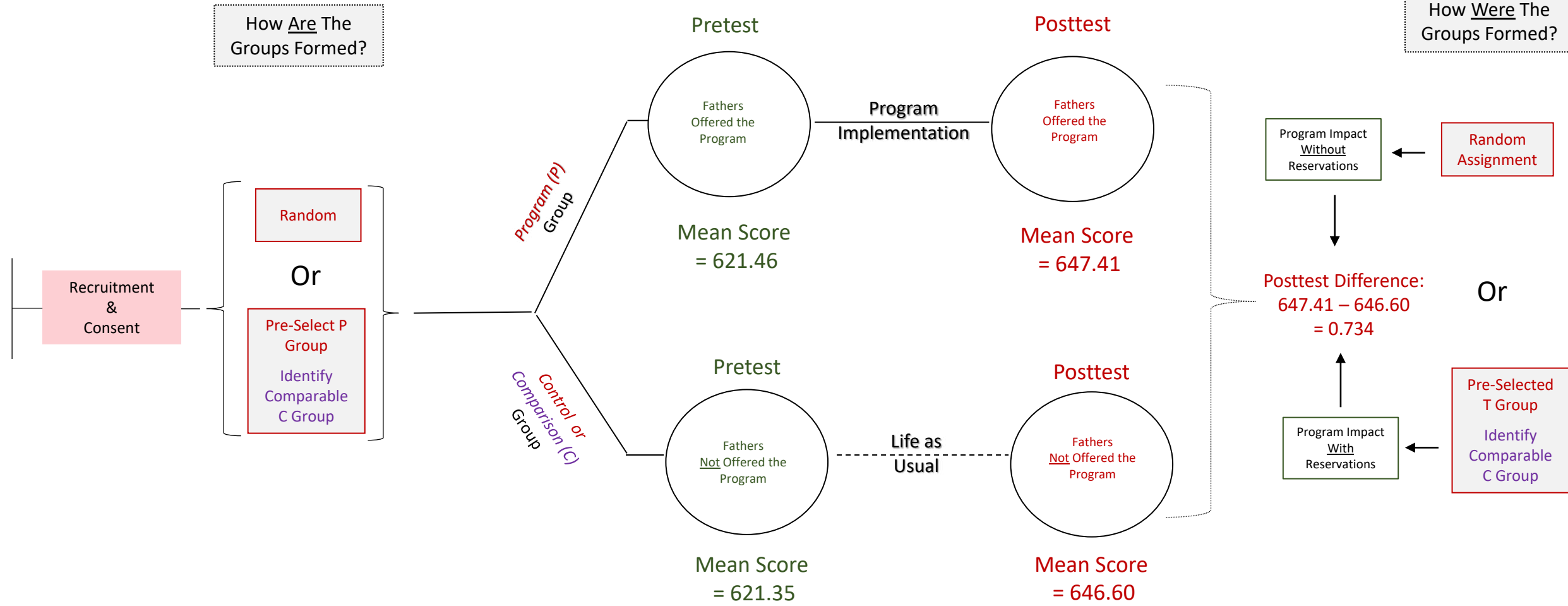

What is the Causal Effect of the Program?

Table 1. Post-Test Results from a Hypothetical Fatherhood Program Impact Evaluation

Outcome	Program Mean	Control Mean	Mean Difference (SE)	Confidence Interval	P-value
Child Reading Score	647.41	646.60			

Note. The standard error (SE) for the post-test mean difference is in parenthesis.

The WWC Founded in 2002

The Fatherhood Learning Academy is hosted by the Healthy Start TA & Support Center at NICHQ.

The First Federally Sponsored Clearinghouse on Systematic Reviews of “What Works” Studies

Over 15,000 Studies Reviewed

A Comparison Group is an *Eligibility Requirement*

The screenshot shows the homepage of the IES WWC Clearinghouse. At the top, it says "IES WWC What Works Clearinghouse" with a search bar and a "Go" button. Below this is a green banner that reads "Select topics to Find What Works based on the evidence". Underneath the banner are several topic icons: Literacy, Mathematics, Science, Behavior, Children and Youth with Disabilities, English Learners, Teacher Excellence, Charter Schools, Early Childhood (Pre-K), K-12 Kindergarten to 12th Grade, Path to Graduation, and Postsecondary. Below the topics are two main sections: "WELCOME TO THE WHAT WORKS CLEARINGHOUSE" and "HIGHLIGHTS". The "WELCOME" section contains a paragraph about the clearinghouse's mission. The "HIGHLIGHTS" section features a featured article titled "What Works Clearinghouse Webinar on Evidence-Based Practices and Programs in STEM" with a brief description and a progress indicator. At the bottom, there is a "QUICK LINKS" section with four icons: Intervention Reports, Practice Guides, Reviews of Individual Studies, and Resources. The footer includes the IES NCEE logo and social media icons for YouTube, Email, Facebook, Twitter, and YouTube.

Fourteen Evaluation Clearinghouses On What Works

Research and Evaluation Clearinghouse	Sponsor	Site Location
1. Best Evidence Encyclopedia	Johns Hopkins University School of Education	http://www.bestevidence.org/
2. Blueprints for Healthy Youth Development	University of Colorado Boulder: Institute of Behavior Science	https://www.blueprintsprograms.org/
3. California Evidence-Based Clearinghouse for Child Welfare	California Department of Social Services'	https://www.cebc4cw.org/
4. Clearinghouse for Labor Evaluation and Research	US Department of Labor	https://clear.dol.gov/
5. Crime Solutions	US Department of Justice	https://crimesolutions.ojp.gov/
6. Cross State High School Collaborative	Seven State Joint Effort	https://www.hsredesign.org/
7. Evidence for ESSA	Johns Hopkins University School of Education	https://education.jhu.edu/2020/02/evidence-for-essa/
8. Ohio's Evidence-Based Clearinghouse*	Ohio Department of Education	https://essa.chrr.ohio-state.edu/getting-started
9. Results First Clearinghouse*	PEW Charitable Trust	https://www.pewtrusts.org/en/research-and-analysis/issue-briefs/2014/09/results-first-clearinghouse-database
10. Self-Sufficiency Research Clearinghouse	U.S. Department of Health and Human Services	https://selfsufficiencyresearch.org/
11. Social Programs That Work	Arnold Ventures	https://evidencebasedprograms.org/about-us/
12. Teen Pregnancy Prevention Evidence Review	U.S. Department of Health and Human Services	https://tpevidencereview.youth.gov/
13. What Works Clearinghouse	US Department of Education's Institute of Education Sciences	https://ies.ed.gov/ncee/wwc/
14. What Works in Reentry Clearinghouse	U.S. Department of Justice.	https://whatworks.csgjusticecenter.org/

Note. An “*” denotes a clearinghouse of clearinghouses. List is not exhaustive.

Pathways to Work: Evidence Clearinghouse

The Fatherhood Learning Academy is hosted by the Healthy Start TA & Support Center at NICHQ.

U.S. Department of Health & Human Services Administration for Children & Families Office of Planning, Research & Evaluation

Site search



Find Interventions That Work Other Pathways Resources About Help

Pathways to Work Evidence Clearinghouse

The Pathways to Work Evidence Clearinghouse is a comprehensive, transparent, and systematic assessment of the effectiveness of interventions designed to help job seekers with low incomes succeed in the labor market.

[Learn more](#)



[View interventions](#) that are currently supporting individuals remotely during the COVID-19 pandemic.

Sponsored by U.S Department of Health & Human Services

Use intervention details

Watch our video to see how to use information about intervention content, effectiveness, and implementation to make decisions.



Accessible video

Sign up for emails

Looking for new, up to date information on interventions that are supported by evidence? Want to receive updates on new publications, opportunities to submit studies, or other events? [Join our email list!](#) Emails will not be shared with other organizations.

CONNECT WITH US



Reviewed to date

The counts below show the number of interventions and studies that are included in the Pathways Clearinghouse.

221 interventions

295 studies

[Find interventions](#) | [Find studies](#)

STAY CONNECTED!

Sign up for updates!*

Knowledge Check: What Makes a Fatherhood Program Evaluable?

Q1. A rigorous or scientific evaluation requires the collection of large amounts of data using the most sophisticated methods and statistics?

- True
- False

Answer: False. A rigorous or scientific evaluation depends on the proper alignment of the questions, methods, data collection, analysis and reporting and proper execution by the evaluator.



Knowledge Check: What Makes a Fatherhood Program Evaluable?

Q2. An evaluator reports that a fatherhood program caused a positive and statistically significant difference in amount of time a father spent with his child during the past year. The evaluator makes this claim based on an increase from pretest to posttest, over one year, for 50 fathers that participated in the program? Based on this claim, what would you conclude?

- A. The program works! It caused a positive increase in the father-child relationship.
- B. The program does *not* work! The number of fathers in the program was too small.
- C. The program is promising, but a study with comparison group of fathers is needed.
- D. The program is associated with the change but may not be the cause of it.
- E. None of the Above

F. C and D

Answer: C and D. At best, a one-group study can show an association and evidence of promise.



4. What Makes a Fatherhood Program Sustainable?

Funding for Fatherhood Programs: Three Questions to Ask

1. How Do You Describe, Implement, Monitor, Improve, and Evaluate Your Program?

2. What Data Do You Collect on Program Delivery, Implementation and Outcomes?

3. What Are Potential Funding Sources that Align with "1." and "2."?



Inputs What are Your Activities? What are Your Outputs? What are Your Outcomes?

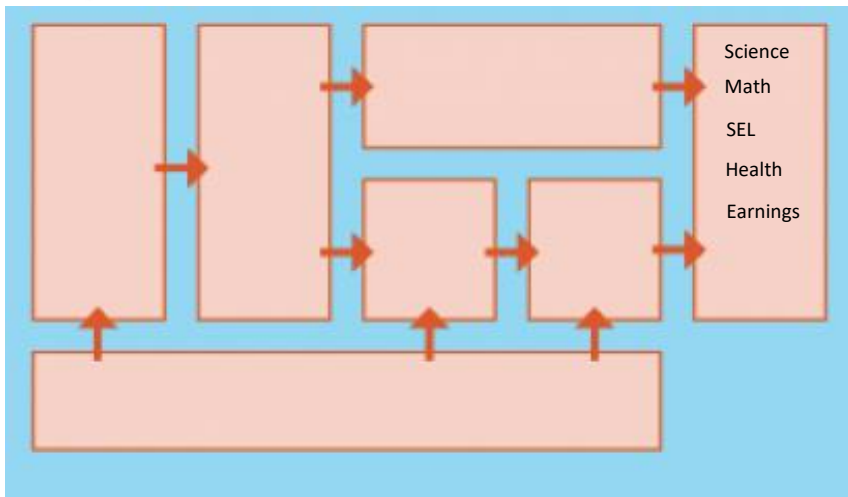

What are Your Program Results?

Who are Your Potential Funders?

Table 1. Post-Test Results from a Hypothetical Fatherhood Program Impact Evaluation

Outcome	Program Mean	Control Mean	Mean Difference (SE)	Confidence Interval	P-value
Child Reading Score	647.41	646.60	0.81 (2.36)	(-3.82, 5.44)	0.81

Note. The standard error (SE) for the post-test mean difference is in parenthesis.

- NSF
- IES
- NIH
- ACF
- DOL

Knowledge Check: What Makes a Fatherhood Program Evaluable?

Q2. A fatherhood program's grant funding will expire within the next two years. New funding will be needed to sustain the program. Which of the follow is a viable strategy for sustaining the program.

- A. Hope that the current funding is somehow extended.
- B. Launch an aggressive media campaign using anecdotes from program participants and staff about how the program changes lives.
- C. Start networking with program funders and hope one of them likes your program and will fund it.
- D. Anticipate RFPs that will be release across federal agencies, align the RFP requirements with your program goals, logic model, evidence, and prepare to write and submit a competitive proposal.
- E. None of the Above

Answer: D. Networking has its place, but there is not substitute for doing the RFP alignment work, generating evidence, and preparing to write a competitive grant proposal



5. What are the Cornerstones of Fatherhood?

Know or learn:

- The why and “how” of this work and its broader implications for communities, stakeholders and funders (e.g., the ecosystem).
- How to systematically describe and present the work starting with a Theory of Change and Logic Model.
- How to identify, collect, and use data to inform, support, and improve the work.
- How to include the work in evaluation: Start with “evidence of promise” and grow to “evidence of what works.”
- How to leverage all of the above to develop a comprehensive strategy to compete for funding to sustain the work.

Cornerstones of Evidence-Based Fatherhood Programs



6. Homework Exercise & Discussion



Questions for Group Discussion

What does your level of agreement with the statements in the inventory tell you about your Program's:

1. Goals?
2. Nature and Structure?
3. Theory and Logic?
4. Evidence Base?
5. Evaluability?



Want to Learn
More?
Contact Today's
Presenters

Contact:

- Dr. Herb Turner:
herb@analytica-inc.com
- Mr. Uriel Johnson:
johnson.uriel@gmail.com

See Pamphlet:

Finding What Works: Guiding
Principles for Fatherhood
Practitioners

Post-Session Readiness Assessment

Survey

- Please scan the QR code or visit <https://link.nichq.org/FatherhoodLASession3> to complete the survey
- Your responses will help shape the future Learning Academy sessions!





Homework & Next Steps

Danisha Charles
Healthy Start TA & Support Center



Homework

- ❑ Complete the “Cornerstones of an Evaluable Fatherhood Program” inventory. The inventory is a checklist that aligns with the content taught in the session and takes on average 15 minutes to complete.
- ❑ Be encouraged to develop teamwork and community learning among groups in completing homework assignments.

Your Journey To Co-Parenting

By Dr. Jeffery Johnson and Monica Johnson

The TA & Support Center is pleased to provide one copy of this book to each Healthy Start project participating in the Fatherhood Learning Academy.

To request a copy for your project, your Project Director must complete the request form by following the link in the chat box or scanning the QR code.



Healthy Start CoLab



- Connect with your fellow Learning Academy participants on the Healthy Start CoLab!
- If you do not have a CoLab account, please email healthystart@nichq.org



Next Healthy Start Fatherhood Learning Academy Session:

**Tuesday, October 26
from 2-4 pm ET**

Can be found on the EPIC website or
bit.ly/hs-deadlines-and-events

October 2021

Deadlines:

Oct 15 HSMED-II Report (CSV or XML) Due

Events:

Oct 12 [Fatherhood Talk Tuesday](#)

Oct 18 TIROE CoP Learning Session #6 – COP members only

Oct 20 Healthy Start COIN Meeting #9 – COIN members only

Oct 26 [Fatherhood Learning Academy Session #4](#)

Oct 28 [CAN Learning Academy Session #6](#)



**Thank
You!**